

**Highly flexible Residual Current Monitor of Type B/B+ for measuring DC and AC residual currents up to 100kHz, with analog 4-20mA and relay output.**

**User selectable Frequency range, Integration time and Rated residual operating current.**

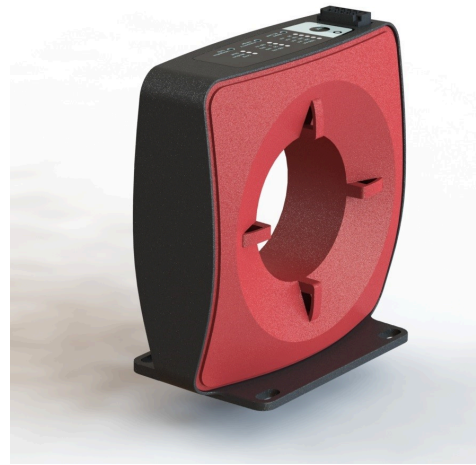

### Features & Highlights

70mm primary cable / busbar aperture

DC and AC residual current measurement of Type B/B+ in the range 0-2Arms up to 100kHz

User selectable:

- Frequency range
- Integration time
- Rated residual operating current

Analog 4-20mA and relay output

Fluxgate current measurement technology with fixed excitation frequency for enhanced accuracy and stability

### Applications:

Residual current monitoring in industry

Condition-based monitoring of insulation health

Replacement of / supplement to compulsory High voltage insulation testing

Scheduling of planned factory maintenance

DC power systems (UPS, PV, LED lighting...)

High frequency loads (SMPS, Motor drives...)

Mission critical (Data centers, Medical ...)



### Background

**Residual currents** (aka Earth fault currents, Insulation leakage currents) are unique measure for the state of the insulation of the electrical power system and its need for maintenance & repair to avoid nuisance shutdowns. Monitoring of the residual currents in real-time in a power system gives the possibility to evaluate the health of the electrical insulation based on the actual value measured, while the long-term development of the residual current value can be used for planning maintenance to avoid significant insulation deterioration. In this way, Residual Current Monitors (RCMs) used in a Condition-based Monitoring scheme as per Industry 4.0 standards can ensure early fault detection and increase the availability of the power system at much lower cost than regular, expensive and time consuming high voltage insulation testing.

Residual currents in electrical power systems can have multiple sources: insulation faults, insulation leakage currents, capacitive displacement currents, EMC filter leakage currents etc. While some of these contributing residual currents are normally present due to material physics when subjected to high or alternating voltages, other contributors are sign of deteriorating insulation which can produce abnormal heat dissipation, short-circuits and in worst case fire and danger to personal safety. Proliferation of DC loads (e.g. LED lighting, DC motor drives, 48Vdc bus systems etc.), DC distributed generation (e.g. PV systems, UPS, batteries etc.) as well as high-frequency converters (e.g. SMPS, motor drives etc.) in industrial environments makes it increasingly difficult to measure reliably insulation faults with traditional RCMs designed for AC 50/60Hz with limited measurement bandwidth. It is the experience of many installers around the world that in order to make the residual current protection work not only now but also in the future with extensions of existing plants, it is necessary for the end-user to have the possibility to select from several residual current limits, different frequency bandwidths and sensitivity levels.

**General description**

**Residual Current Monitors (RCMs)** are used for monitoring of the residual currents in electrical power systems without the need for fast system shutdown. The RCM of Type B/B+ can measure DC and AC residual currents at frequencies of up to 100kHz, which makes it compatible to multitude of industrial applications, loads and generation sources. With its user selectable settings, this RCM offers flexible platform for residual current measurement which fits every possible usage both at the moment the industrial plant is designed, but also in case of extensions with new modern loads operating with DC voltages or at high switching frequencies which increase the amount of leakage current in the system.

The RCM product features an analog 4-20mA output which represents the real-time True RMS (TRMS) value of the measured residual current for interfacing to e.g. a PLC. Additionally a free potential relay output (NO / NC) with user selectable rated residual current limit can be used for warning or even system shutdown when the TRMS residual current measurement has exceeded the preset value. The status of the relay output is replicated to a LED for visual indication on the device itself. Built-in test button and external test button input are provided for regular testing of the RCM as per applicable product standards. Only a single 24Vdc power supply should be provided for powering the RCM.

Intended for use in Single-phase and 3-wire & 4-wire Three-phase systems.

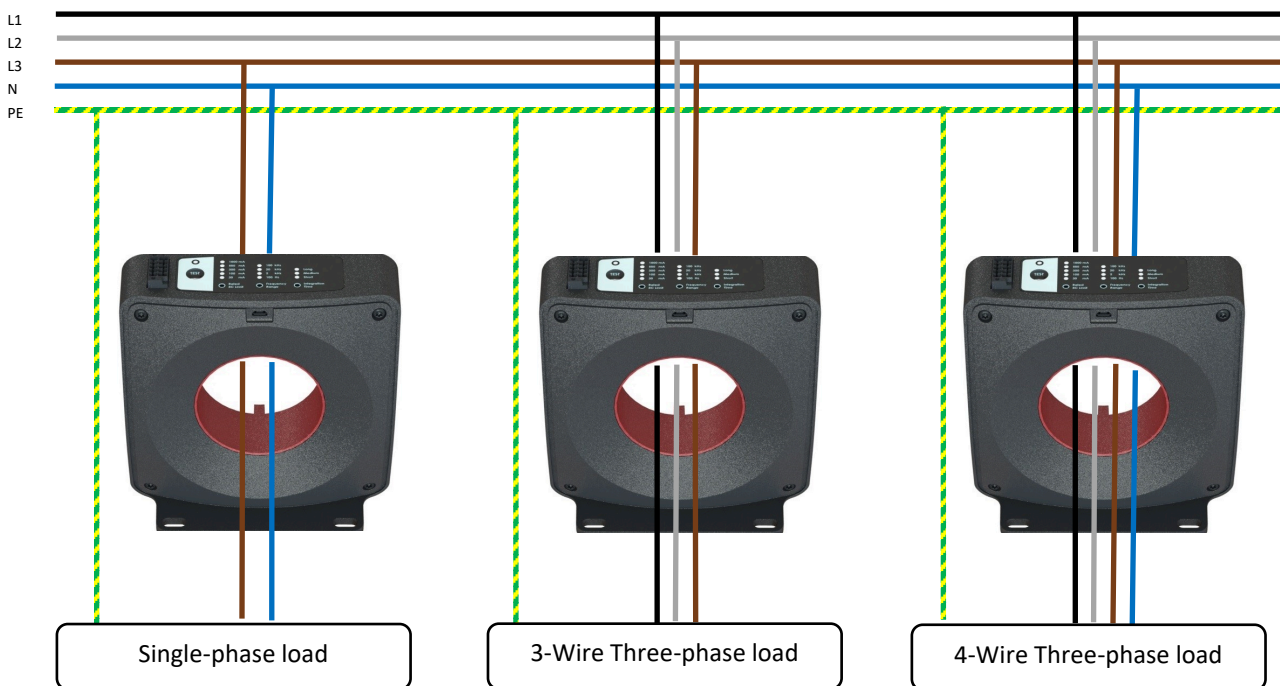

**Connector**

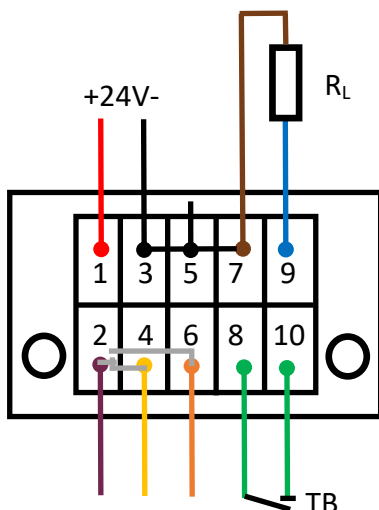

**Pinout:**

- 1: 24Vdc
- 2: Relay common
- 3: 0Vdc
- 4: Relay NC contact
- 5: 0Vdc
- 6: Relay NO contact
- 7: 0Vdc
- 8: External Test button, contact 1
- 9: Analog 4-20mA output
- 10: External Test button, contact 2

**User interface description**

This RCM product features three user selectable parameters, each with the choice of selecting 3-5 different values. The simple and intuitive user interface can be found on the top of the RCM and is used for configuring the RCM with three buttons located below the surface level. These buttons can only be operated with a tool which prohibits unintentional and unauthorized access, as per applicable product standards. Interface features furthermore a Test button and status LED for visual indication.

**Power-on / Status LED**

Lights in green colour with heart-beat\* during normal operation with low residual currents. Changes colour to red with heart-beat when the measured TRMS of residual current is higher than the rated RC limit.

Flashing green light during start-up. Constant red light combined with multiple flashing green LEDs from "Rated RC limit" group indicates fault status.

\*Light intensity of the status LED changes continuously in a heart-beat fashion to mark correct execution of the software. It is a mere indication of the RCM being awake and taking care of user assets.

**Fault codes**

- Input voltage out of range
- Relay activated too many times
- Overtemperature
- Internal failure
- flashing — LEDs from left group (RL)

**Test button**

It is used to activate the test sequence for testing the operation of the RCM.

Successful test will activate the relay and cause LED to turn red.

When relay is latched due to too many activations, pressing the button for 3s will reset the condition if residual current is normal.

**Integration time (IT)**

Refers to the time window for calculating TRMS value. Hints:

- Longer IT makes the RCM less sensitive to short peaks during startup situations; better for low frequency operation
- Shorter integration times result in faster RCM response, especially if short residual current pulses are of interest

**Frequency range (FR)**

Refers to the measurement bandwidth for the residual current. Hints:

- If only DC and low frequency AC (50/60Hz) are of interest, use the 100Hz setting
- If protection of switch-mode frequency converters is imperative, increase FR towards 2kHz, 20kHz or even full bandwidth 100kHz

**Rated RC Limit (RL)**

Refers to the measured TRMS value of the residual current which will trip the relay output. Additionally, selecting the three lower trip limits (30-100-300mA) changes the analog output range to 0-0.4Arms, while selecting the two higher trip limits (500-1000mA) changes the analog output range to 0-2Arms. Hints:

- Set the RL low if it is required to get early warning of increasing residual current levels
- To avoid nuisance alarms, set RL to higher values which correspond to the residual current levels the user can tolerate in the electrical power system before system check or maintenance is going to be required

**Functional description**

DanisenSense Residual Current Monitor senses the instantaneous, real-time value of both DC and AC residual current using the built-in transducer head with integrated balanced Flux-gate detector. For the purpose of functional protection and especially fire protection of the electrical power system, the RCM implements the True RMS (TRMS) value of the residual current which corresponds to the amount of heat dissipated in the insulation. In order to provide high level of flexibility in the RCM usage and fit to as many potential applications as possible, this RCM is equipped with three user-selectable parameters which affect the final TRMS value indicated at the analog 4-20mA output as well as the relay output and status LED.

The "Frequency range (FR)" parameter limits the frequency bandwidth of the measured residual currents. After the frequency range of interest have been selected, the "Integration time (IT)" parameter determines the length of the integration window for the TRMS value. Finally the TRMS value is scaled according to the selected "Rated RC limit" into two different ranges (details in the electrical specification tables). After these intermediate steps, the TRMS value of the residual current is ready to be sent out to the analog 4-20mA output. The behavior of the relay output and status LED is though influenced by couple of extra processing blocks, as described below.

The "Rated RC limit (RL)" sets the level at which, when violated by the Weighted TRMS, the relay output and status LED will toggle the state. Weighted TRMS is obtained from the TRMS value by applying a weighting filter which attenuates the residual currents with higher frequencies while passing entirely the low frequency residual currents, as per applicable product standards. The reason for this choice is that higher values of high-frequency residual currents appear naturally in switch-mode power converters when fast changing voltages are applied to e.g. cable insulation, output dv/dt filters, input EMC filter and Y capacitors to ground.

Decision on relay output status is done with a comparator having a hysteresis, meaning that after activation of the relay the residual current TRMS value needs to reduce by a certain hysteresis before the relay output is deactivated. In case of repetitive activation & deactivation of the relay, it is latched to activated state and Test button needs to be pressed for at least 3s to reset.

**Block diagram**

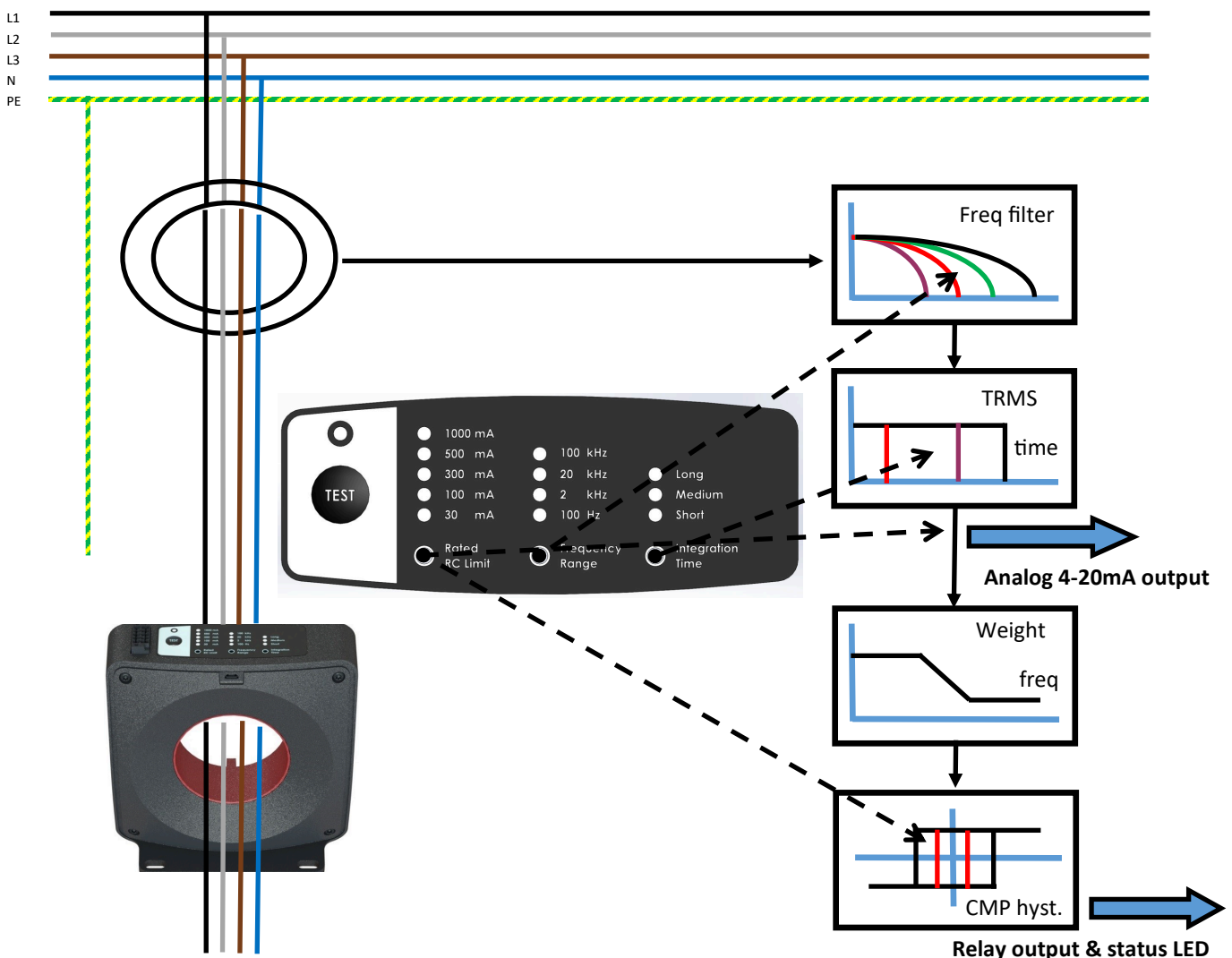

**Auto setup**

**Danisense RCM** is capable of performing automatic setup of the user selectable settings for installations in proper condition taken as baseline. This means that when the auto setup is initiated, the RCM will automatically measure the residual currents at the location of the installation with different frequency ranges & integration time settings and select the rated residual current limit which is at least 50% higher than the measured value. In this way the RCM will operate with comfortable margin for future development of the measured residual current towards the trip limit of the relay. The auto setup will also propose an appropriate frequency range and integration time.

**Necessary steps:**

- Activate the auto setup by pressing "Rated RC limit" and "Integration time" buttons simultaneously for more than 3s
- RCM will perform sequence of residual current measurements with different settings
- Proposed settings for "Rated RC limit", "Frequency range" and "Integration time" are marked with flashing LEDs
- The proposed change of settings should be accepted by pressing the "Test" button
- If the change is not accepted within 10s, the RCM will revert back to the old settings

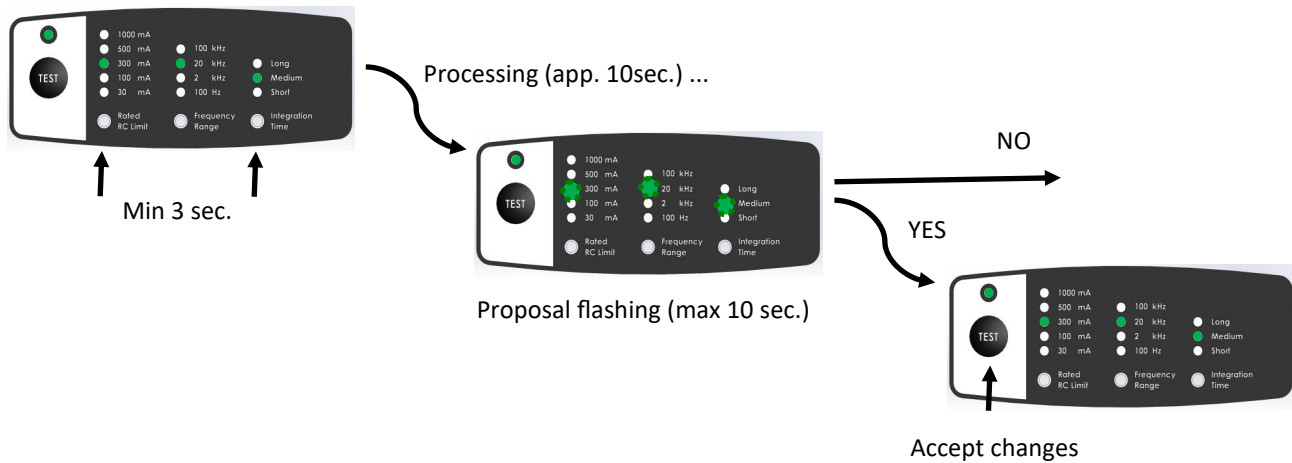

NB: Frequency range of 100Hz is not included in the auto setup feature i.e. if desired the user must select it manually. The RCM will always give priority to settings which make the RCM more sensitive i.e. higher frequency ranges and shorter integration times.

## Electrical specifications

### Primary monitored circuit

Parameter	Symbol	Value
Rated voltage of monitored circuit	$U_n$	690Vrms
Rated frequency of monitored circuit	$f_n$	50Hz / 60Hz
Applicable operating frequency range of monitored circuit	$f_{aop}$	0-400Hz
Rated primary current	$I_n$	100A ( $I_{\Delta n}=30mA$ ) 300A ( $I_{\Delta n}=100-1000mA$ )
Max. non-tripping overcurrent	$I_{max}$	600A ( $I_{\Delta n}=30mA$ ) 1800A ( $I_{\Delta n}=100-1000mA$ )
Thermal rated short-time (10ms) withstand residual current	$I_{\Delta th}$	200A
Thermal rated continuous withstand residual current	$I_{\Delta cth}$	100A
Rated impulse residual current	$I_{\Delta dyn}$	10kA
Rated insulation voltage	$U_i$	700V
Impulse withstand voltage	$U_{imp}$	8kV
Overvoltage category	OVC	IV
Pollution degree acc. EN/IEC 60664	PD	3

### Residual current characteristics

Parameter	Symbol	Value
Rated relay output residual current at 50/60Hz – user selectable Rated RC limit	$I_{\Delta n}$	30mA-100mA-300mA- 500mA-1000mA
Residual current frequency range – user selectable	$f_{\Delta n}$	DC-100Hz* DC-2kHz DC-20kHz DC-100kHz
Relay output residual operating current at 50/60Hz	$I_{\Delta n}$	100% $I_{\Delta n}$ +0%-20%
Relay output residual non-operating current at 50/60Hz	$I_{\Delta no}$	50% $I_{\Delta n}$ +20%-0%
Frequency dependence of residual operating current	$I_{\Delta n, freq}$	150Hz: 2.4· $I_{\Delta n}$ (or 2Arms max) 400Hz: 6· $I_{\Delta n}$ (or 2Arms max) 1000Hz: 14· $I_{\Delta n}$ (or 2Arms max)
Frequency dependence of residual non-operating current	$I_{\Delta n, freq}$	150Hz: 0.5· $I_{\Delta n}$ 400Hz: 0.5· $I_{\Delta n}$ 1000Hz: 1· $I_{\Delta n}$
Rated analog output residual current (20mA)	$I_{an}$	0.4Arms ±2% ( $I_{\Delta n}=30-300mA$ ) 2Arms ±2% ( $I_{\Delta n}=0.5-1A$ )
Hysteresis on relay output (for non-latched operation)	$I_{\Delta n, hyst}$	<30% $I_{\Delta n}$
Integration time	$T_i$	Short (100ms) Medium (400ms) Long (1000ms)

All values are True RMS (TRMS) values

\* 100Hz frequency range makes RCM insensitive to higher frequencies and is not Type B compliant acc. to IEC62020-1

### External Test and Reset button

Parameter	Symbol	Value
Cable length for external Test & Reset key	$L_{tk}$	≤ 10m
Short-circuit current	$I_{sc,tk}$	<4mAdc, SC-proof
Voltage at open terminals	$U_{oc,tk}$	24Vdc

**Analog current interface 4-20mA**

Parameter	Symbol	Value
Current output 0-0.4Arms / 0-2Arms	$I_{out}$	4-20mAdc
Current output at 0% $I_{\Delta n}$	0%	4-4.2mAdc
Current output at 0.4Arms / 2Arms	100%	19-21mAdc
Peak-to-Peak noise	pk-pk	$\leq 0.25\%$
Resolution	$Res_{out}$	0.01mA
Short-circuit current	$I_{sc,out}$	<25mAdc, SC-proof
Maximum total load resistance / apparent ohmic resistance with cable	$R_{t,max}$	$\leq 900\Omega$
Typical load resistance	$R_{typ}$	250 $\Omega$
Voltage at open terminals	$U_{oc,out}$	24Vdc
Response time 1x $I_{\Delta n}$ , step response 10-90%	$t_{10-90\%}$	$\leq T_i$
Response time 1x $I_{\Delta n}$ , step response 0-50%	$t_{0-50\%}$	$\leq T_i/2$
Response time 5x $I_{\Delta n}$ , step response 10-90%	5x $t_{10-90\%}$	$\leq T_i/30$
Response time 5x $I_{\Delta n}$ , step response 0-50%	5x $t_{0-50\%}$	$\leq T_i/50$

**Relay output**

Parameter	Symbol	Value
Contact output		NO+NC
Rated voltage	$U_r$	30Vac/dc
Rated current	$I_r$	1Aac/dc
Maximum actuating time 1x $I_{\Delta n}$	$t_r, 1x I_{\Delta n}$	$\leq T_i + 1/(2 \cdot f_{rc})^*$
Maximum actuating time 5x $I_{\Delta n}$	$t_r, 5x I_{\Delta n}$	$\leq T_i/16 + 1/(2 \cdot f_{rc})^*$
Response threshold $I_{\Delta n}$		100% +0-20%
Latching function with Reset (int/ext)		Yes
Minimum non-actuating time	$t_{nr, 1x I_{\Delta n}}$	$\leq T_i/2$
Switching operations		>20.000

\*  $f_{rc}$  is the frequency of the dominant residual current component

**Supply voltage**

Parameter	Symbol	Value
Rated supply voltage*	$U_e$	24Vdc +10%/-15%
Overvoltage category	$OVC_e$	III
Rated impulse withstand voltage	$U_{impe}$	1.5kV
Rated insulation voltage	$U_{ie}$	30V
Internal consumption	$P_e$	<4W

\* External adapter



**CAUTION:**

- PLEASE IMPERATIVELY RESPECT CONNECTION POLARITIES TO PREVENT DESTRUCTION OF THE RESIDUAL CURRENT MONITOR
- PLEASE ENSURE ADEQUATE CURRENT AND VOLTAGE RATING OF POWER SUPPLY TO AVOID MALFUNCTION

**Environmental and mechanical characteristics**

Parameter	Unit	Min	Typ	Max	Comment
Operating temperature range	°C	-20		55	
Storage temperature range	°C	-40		85	
Relative humidity	%	20		80	Non-condensing
Mass	kg		0.9		
Connector	Phoenix Contact DFMC 1.5-3.5 2x5way PN: 1790519, or compatible				
Standards	EN / IEC 62020-1:2020				

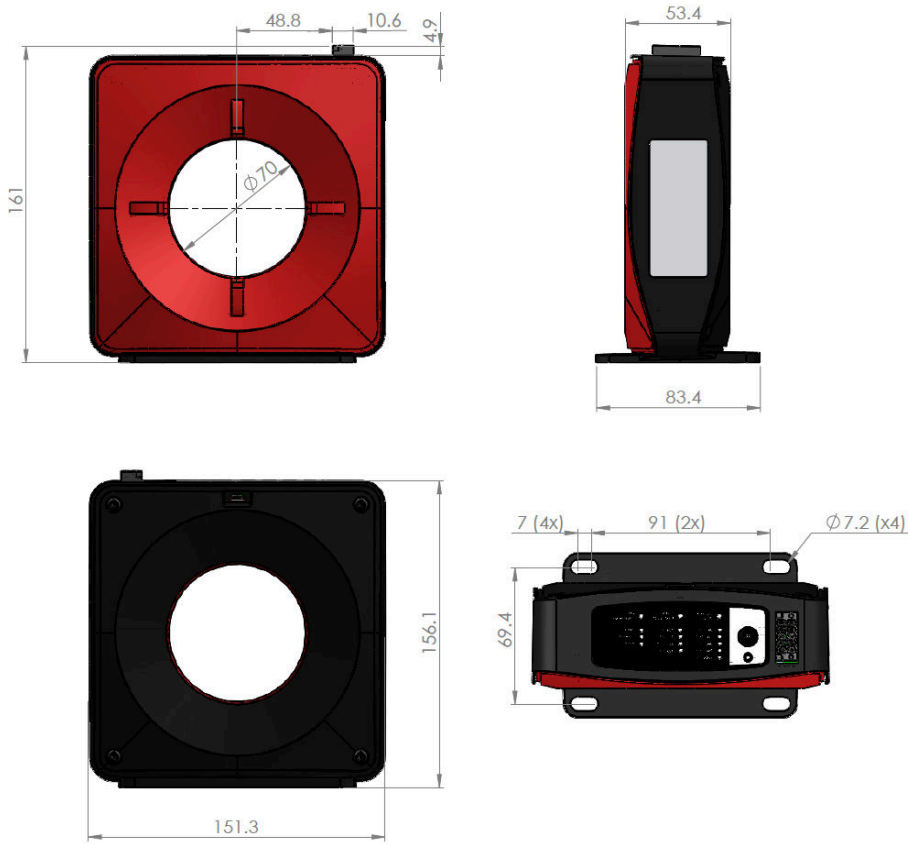
**Mechanical specifications**



(general tolerance 0.3mm unless otherwise stated)

**Mounting instructions**

- Base plate mounting with screws in the four holes
- Free-hanging on the cable by using cable strips through the hooks on the backside for fixation

