

Compact precision fluxgate AC/DC current transducer for galvanically isolated measurement 4000 A_{RMS}

Features

- Precision current transducer based on the stable Danisense closed loop flux gate technology
- Ø121mm aperture
- Current measurement accuracy < 0.05%
- Current output
- Sensitivity < 2uA/A
- Primary/secondary ratio 1:5000
- Low offset drift over temperature

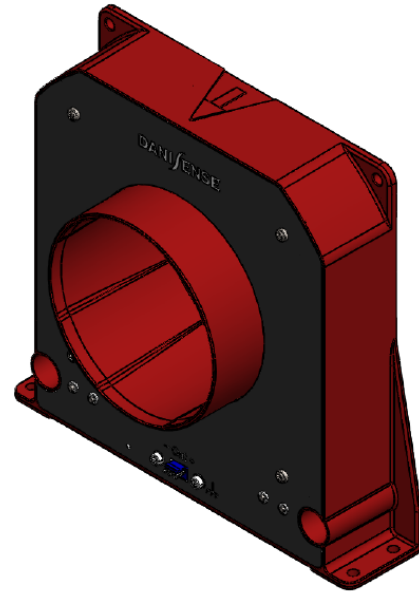

Electrical specifications at Ta=23°C, Vs = ±24 V supply voltage

Parameter		Symbol	Unit	Min	Typ.	Max	Comment
AC current		I _{PN AC}	A _{RMS}			4000	Vs = ±24V & R _M ≤ 1Ω
Nominal primary DC current		I _{PN DC}	A	-4000		4000	Vs = ±24V & R _M ≤ 1Ω
Primary current, measurement range		I _{PM}	A	-7000		7000	Vs = ±24V & R _M ≤ 1Ω
Current consumption		I _C	mA		100 + I _S		1.25A @ I _{PM}
Nominal secondary current		I _{SN}	A	0.8		0.8	@ I _{PN DC}
Primary / secondary ratio				1:5000		1:5000	I _{primary} /I _{secondary}
Measuring resistance		R _M	Ω	0	1		
Linearity error		ε _L	%	0.01			% refers to reading
Bandwidth		f(-3dB)	kHz	100 kHz			
Response time to I _{PN} ramp step signal		μs		0.5			400A/μs @4000A
Temperature variation of I _O , referred to primary		I _{OT}	A	±0.4			-40 ... 85 °C; 0.4A @ 0.01%
Offset current, referred to primary		I _O	A	±0.4			-40 ... 85 °C; 0.4A @ 0.01%
Magnetic offset current after 3 x I _{PN} Referred to primary		I _{OM}	A	±0.4			-40 ... 85 °C; 0.4A @ 0.01%
Sensitivity error		ε _G	%	±0.03			% refers to nominal current
Overall accuracy		ε _{TOT}	%	-0.05		0.05	% refers to nominal current -20 ... 85 °C
Power supply voltages		V _{DC}		±14.5		±25.2	
Operating temperature range			°C	-40		85	

Isolation specifications

Parameter	Unit	Value
Rms voltage for AC isolation test, 50/60 Hz, 1 min - Between primary and (secondary and shield)	kV	6
Partial Discharge extinction voltage rms @ 10pC	kV	2
Impulse withstand voltage 1.2/50us	kV	23
Creepage distance	mm	>38
Clearance distance	mm	>38
Over Voltage Category		OV3
Comparative Tracking Index	CTI	600

Environmental and mechanical characteristics

Parameter	Unit	Min	Typ	Max	Comment
Storage temperature	°C	-50		90	
Relative humidity	%	20		80	Non-condensing
Mass	kg		4.1		
Pollution degree	PD2				
Case Material	UL94 V-0				
Connections	<p>3 pin: JST-S3P-VH & dV/dt Shield connection</p>				

Mechanical drawings

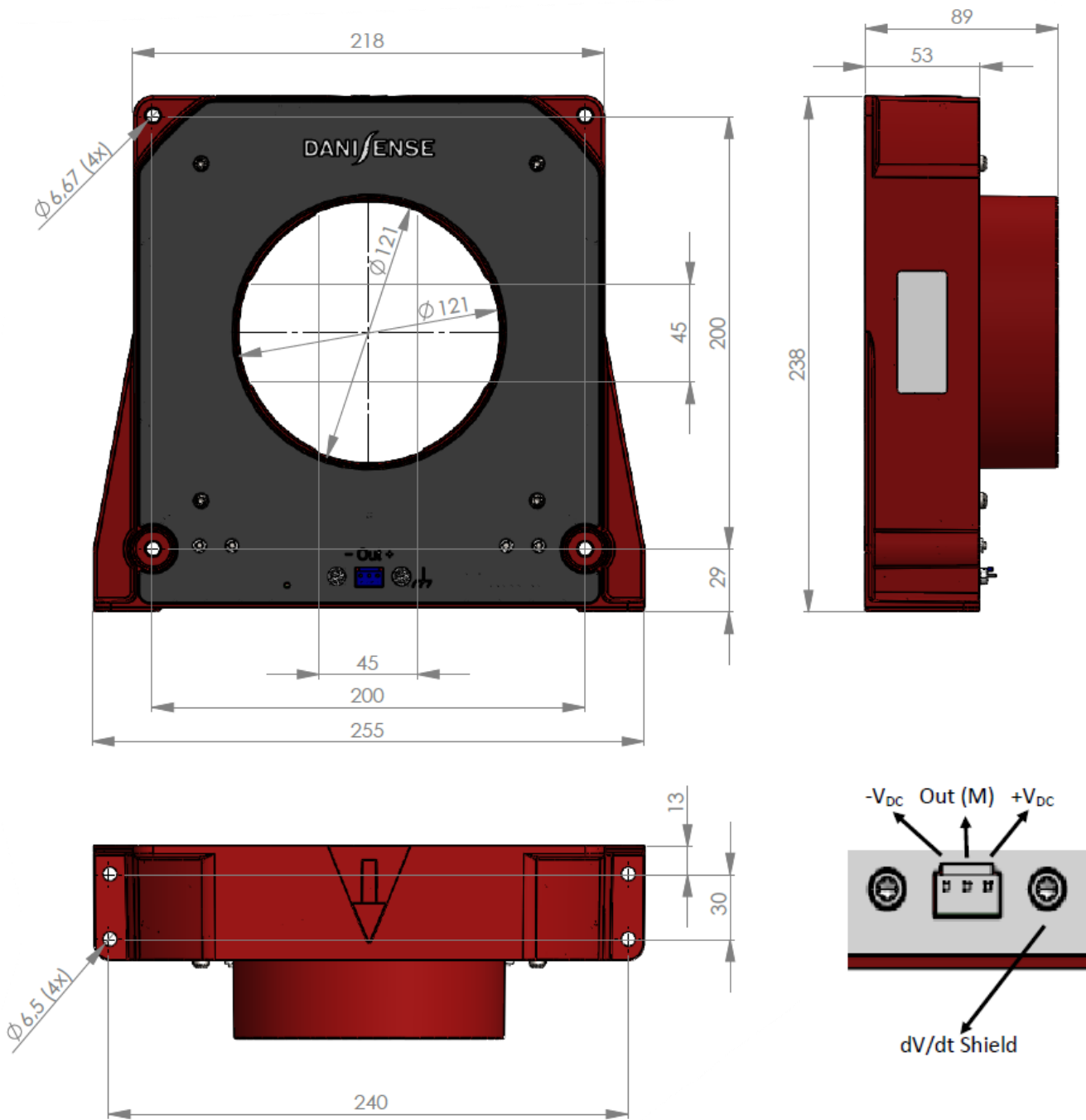

Primary current busbar recommendations for optimal performance

- Center the primary busbar going through the MBC4000I Ø121mm aperture.
- At 7000A DC recommended distance is minimum 350mm. Please see drawing below for illustration.
- At 4000A DC recommended distance is minimum 200mm. Note linear relation to primary current level: $4000A/7000A * 350mm = 200mm$.

 - Sensor position

